

OSE120 OSE120P



The OSE120 is perfectly suited for intense picking in a tough industrial environment. With excellent driving characteristics and the possibility for dual-pallet handling, it greatly improves productivity in the order picking process. Key words are cost efficiency and safety.



Technical Details		OSE120 / OSE120P
Power unit		Electr. battery
Operating type		Stand on
Rated capacity	kg	1200
Load centre	mm	1200
Weight without battery, short chassis/long chassis	kg	1184/1263
Max. axle load castor wheels, without/with rated load, short chassis	kg	407/302
long chassis		395/110
Max. axle load drive wheel, without/with rated load, short chassis	kg	545/562
long chassis		798/725
Max. axle load fork wheels, without/with rated load, short chassis	kg	246/300
long chassis		913/1138
Drive wheel, Vulkollan	mm	Ø250x75
Fork wheels, bogie, Vulkollan	mm	Ø85x75
Castor wheels, Vulkollan	mm	Ø150x75
Travel speed, without/with rated load	km/h	12/8 ¹⁾
Lift speed, without/with rated load	m/s	0.15/0.10
Lowering speed, without/with rated load	m/s	0.15/0.15
Gradient, without/with rated load	%	5/5
Service-/parking brake		1 stage electromagnetic brake
Drive motor/Intermittent rating	kW/%	2.5/60
Lift motor/Intermittent rating	kW/%	1.2/4.5
Battery (5h discharge)	V/Ah	24/200—600
Battery weight, min./max.	kg	250/380
Steering system		electronic
Speed control		stepless
Steering arc	°	200

Dimensions, mm		OSE120 / OSE120P
x	Back of fork to bogie wheel centre, short/long support arms	858/973
y	Wheel base, short chassis, short/long support arms	2042/2157
	long chassis, short/long support arms	2128/2243
h ₇	Instep height	138
h ₁₂	Stand height, elevated	980 ²⁾
h ₁₃	Height of lowered fork	85
h ₁₅	Height of back rest	1370/2199
h ₂₃	Total lift height	800
l ₂	Truck length incl. back of fork, short/long chassis	1406/1492 ³⁾
b ₁	Chassis, width	790
s	Fork thickness	70
e	Fork width	180
l	Fork length	1150—2350
b ₅	Width across fork, min./max.	520/570
m ₁	Floor clearance under mast	23.5
	Turning radius	
W _a	short chassis, short/long support arms	2271/2386
	long chassis, short/long support arms	2357/2472
l ₉	Platform length	450

1) OSE120P = 6 km/h with platform lifted above 500mm

2) Applies only to OSE120P. h₇ remains 138mm

3) Depending on battery compartment

Truck performance and dimensions are nominal and subject to tolerances.
BT Products AB products and specifications are subject to change without notice.
All data is based on VDI 2198.

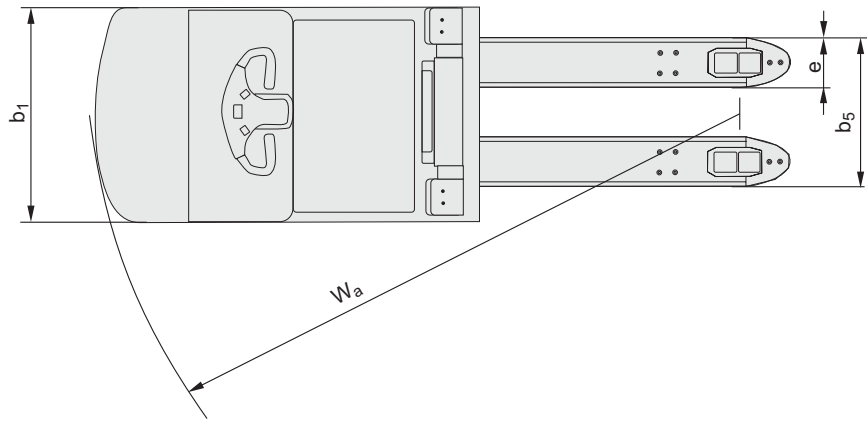
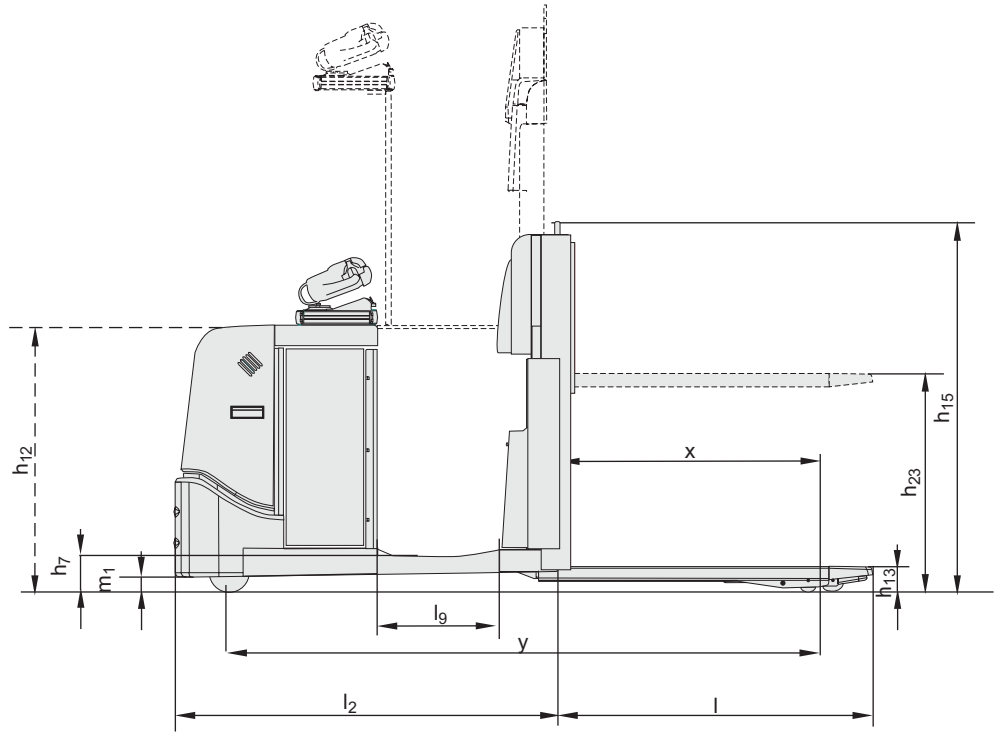



- The new E-MAN steering concept is ideally suitable for picking as well as for pallet handling applications. Light, one hand operation increases the flexibility for the driver and the same time simplifies driving in the fork direction.
- For easy second level picking OSE120P with elevating platform, offers a design which optimizes the total picking cycle. Both efficiency and manoeuvrability increases as the operator always has the E-MAN handle within close reach.
- Dual-pallet handling, with fork lengths up to 2350 mm the OSE120 excels on the market of fork lifting order pickers.
- The performance of the OSE120 is first-rate. A travel speed of 12 km/h, together with high acceleration, increases the number of pick-ups. With our motor technology it is very easy to adjust top speed, acceleration and speed reduction to meet individual requirements.
- The BT POWERDRIVE system provides reliability and simplicity. CAN-bus technology means fewer parts and reliable transmission of data. A PIN code start up procedure offers higher operational safety by stopping unauthorised driving.

Truck features	OSE120	OSE120P
BT Powerdrive System	S	S
Elevating platform	—	S
High performance models	S	S
Controls and instrument		
Adjustable BT Control console	O	O
Exterior lift/lower buttons	O	O
Fingertip controls	S	S
Information display	S	S
Power/Electronic steering	S	S
Driving features		
200° steering	S	S
Automatic deceleration	S	S
Electronic regenerative brakes	S	S
Safety features		
BT Access Control	S	S
Driver detection system	S	S
Programmable performance	S	S
Drivers compartment features		
Elevating picking shelf	—	O
Folding seat	O	—
Low step-in	S	S
On-board data terminal mount	O	O
Storage compartments	O	O
Writing table	O	O
Maintenance features		
Easy access for maintenance	S	S
Fault diagnosis facility	S	S
Battery management features		
Battery change facility	O	O
Battery status indicator	S	S

S = Standard feature

O = Optional feature

— = Not available



The product complies with the EC-directives



SS-EN ISO 9001, No. 003
ISO 14001, No. M005

BT Industries AB
SE-595 81 MJÖLBY
Tel: +46 - (0)142/860 00
Fax: +46 - (0)142/860 80



Handling innovation