

OME100MW
OME100W

The OME-series offers a complete range of pickers which suits a variety of operations in food distribution as well as other industries such as the distribution of household appliances, automotive parts, pharmaceuticals, electronics etc.



Technical Details		OME100MW	OME100W
Power unit		electrical, battery	
Operating type		stand on	
Rated capacity	kg	850/1000	850/1000
Load centre	mm	600/500	600/500
Weight without battery	kg	1620 ¹⁾	1360
Wheel type, fork side/drive wheel side		polyurethane	
Wheel dimension, fork side	mm	Ø 230 x 85	Ø 230 x 85
Wheel dimension, drive wheel side	mm	Ø 250 x 75	Ø 250 x 75
Number of wheels, fork side/drive wheel side		2/1	2/1
Travel speed, without/with rated load	km/h	9/9	9/9
Service brake, hand operated		2 stage electromagnetic brake	
Parking brake, (dead man's grip)		2 stage electromagnetic brake	
Lift speed, without/with rated load	m/s	0,25/0,20	0,25/0,20
Lowering speed, without/with rated load	m/s	0,37/0,40	0,37/0,40
Drive motor/Intermittent rating	kW/%	1,8/60	1,8/60
Lift motor/Intermittent rating	kW/%	5,0/20	5,0/20
Battery weight	kg	360—500	360—500
Battery (5h discharge)	V/Ah	24/480—600	24/480—600
Steering system		electronic power steering	
Speed control, number of steps		transistor, stepless	

1) $h_{12} = 4200\text{mm}$, $b_1 = 970\text{mm}$

Dimensions, mm		OME100MW	OME100W
x	Front axle to fork back	225	225
y	Wheel base	1441	1441
h_7	Instep height	300	300
b_{10}	Track width fork side c/c	850	850
z_{11}	Width between rails, min	$b_1 + 200/230$ ¹⁾	$b_1 + 200/230$ ¹⁾
h_{13}	Height of lowered fork	80	80
l_{21}	Load frame length std, inside	820/1020/1220 ²⁾	820/1020/1220 ²⁾
b_{21}	Load frame width std, inside	890/1090/1290 ³⁾	890/1090/1290 ³⁾
l_2	Truck length incl. back of fork	1870	1870
l_{20}	Cab length, floor	700	700
l_{24}	Entrance width	425	425
b_1	Chassis, width	970	970
b_2	Cab width	1000/1200/1400	1000/1200/1400
s	Fork thickness	62	62
e	Fork width	115	115
l	Fork length	850/1050/1250	850/1050/1250
b_5	Width across fork	560/685/776	560/685/776
m_2	Floor clearance mid wheelbase	60 ⁴⁾	60 ⁴⁾
W_a	Turning radius	1660	1660
h_6	Height of cab	2390	1450
h_{21}	Height of cab inside	2030	—
h_{22}	Height of cab sides	900	900

- 1) Depending on type of rails
(low profile rails: +200mm, high profile: +230mm)
- 2) Outside: + 80 mm
- 3) Outside: + 120 mm
- 4) 25 mm if wire guided

Truck performance and dimensions are nominal and subject to tolerances.
BT Products AB products and specifications are subject to change without notice.
All data is based on VDI 2198.

Mast, mm		OME100MW					OME100W
h_{12}	Platform height	2000	2950	3600	4200	4700	1750
h_1	Height of truck, min.	2400	2400	2400	2650	2900	1460
h_3	Lift movement	1700	2650	3300	3900	4400	1450
h_4	Height of truck, max.	4150	5080	5760	6350	6850	2940
h_{20}	Picking height	3600	4550	5200	5800	6300	3350
h_{23}	Total lift height ¹⁾	1780	2730	3380	3980	4480	1530

1) $h_{23} = h_{13} + h_3$

OME100MW

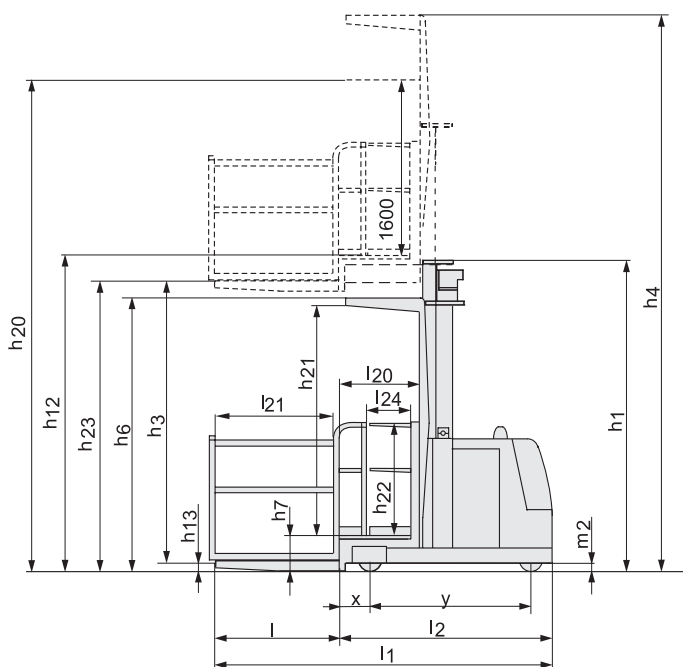

OME100W

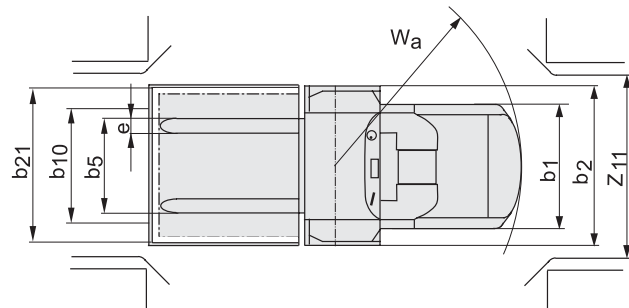
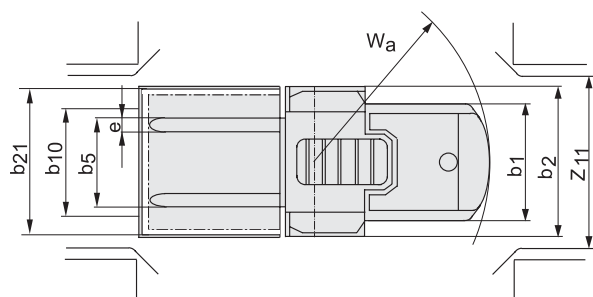
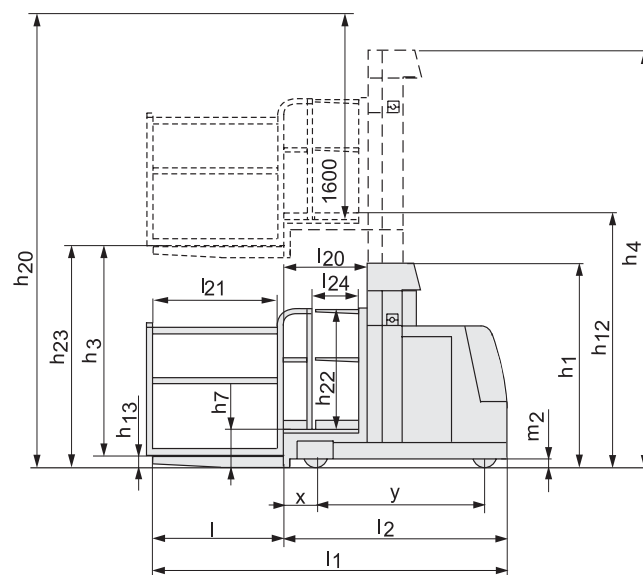



- Optipace allows maximum acceleration rate and travel speed at all heights. The system continuously monitors the position of the truck and cab height and at all times optimizes speed and acceleration accordingly.
- Display showing lift height, clock, battery status, drive wheel position, warnings and error codes etc.
- Stable gates with folding threshold together with a flat floor allows comfortable and safe picking throughout the shift.
- The compact size of the truck in combination with the advanced BT electronic steering and fingertip touch controls, facilitates fine positioning and confident driving in or outside of the aisle.
- A complete auto test routine is carried out every time the machine is turned on. Continuous repetition during operation ensures safety.
- The service and maintenance is straight forward with easy access to all components. LEDs and a digital display allow rapid fault diagnosis.

Truck features	OME100MW	OME100W
Elevating platform	S	S
Choice of cab widths	S	S
Wire/rail guidance	O	O
Controls and instruments		
Adjustable BT Control console	S	S
Information display	S	S
Height indicator	S	S
Hour meter	S	S
Driving features		
Electronic braking system	S	S
Electronic speed control	S	S
Electronic steering	S	S
Safety features		
Automatic parking brake	S	S
BT Optipace system	S	S
Clear-view mast	S	S
Driver detection system	S	S
Emergency cut-off	S	S
Lift height limitation with override	O	—
Warning beacon	S	—
Drivers compartment features		
Storage compartments	S	S
Maintenance features		
Fault diagnosis facility	S	S
History fault log	S	S
Battery management features		
Battery status indicator	S	S
Side-ways battery change	S	S

S = Standard feature

O = Optional feature

— = Not available