

LHM230
LHM230Q
LHM300



The BT Lifter is the universal Hand Pallet truck, suitable for moving loads in all types of applications. Lifting capacity 2.300kg. The BT Lifter is available in different versions and with many options. Our standard versions are covered by lifetime guarantee.



Technical Details		LHM230	LHM230Q	LHM300 ³⁾
Rated capacity	kg	2300	2300	3000
Weight	kg	65	65	105
Steering wheel	mm	Ø 175x60	Ø 175x60	Ø 175x60
Fork wheels, single/bogie	mm	Ø 85x100/Ø 85x75	Ø 85x100/Ø 85x75	—/Ø 85x75
Pump force, rated capacity	kg	34	34	—
Pulling force		19 ¹⁾	19 ¹⁾	—

Dimensions, mm		LHM230	LHM230Q	LHM300 ³⁾
x	Front axle to fork face	985	985	985
y	Wheel base	1217	1217	1217
h ₁₃	Height of lowered fork	85	85	85
h ₃	Lift height	200	200	200
h ₁₄	Height of handle in neutral pos.	1220	1220	1220
l ₂	Truck length incl. back of fork	356	356	356
b ₁	Chassis, width	520/685 ²⁾	520/685 ²⁾	520/685 ²⁾
s	Fork thickness	45	45	45
e	Fork width	156	156	175
l	Fork length	800/910/1000/1070/ 1150/1220 ²⁾	800/910/1000/1070/ 1150/1220 ²⁾	800/910/1020/1070/ 1150/1220 ²⁾
b ₅	Width across fork	520/685 ²⁾	520/685 ²⁾	520/685 ²⁾
m ₂	Floor clearance mid wheelbase	40	40	40
A _{st}	Aisle width, min (Pallet 800x1200 mm)	1756	1756	1756
W _a	Turning radius	1392	1392	1392

- 1) With rated capacity on a smooth, dry level concrete floor
2) Other fork lengths and widths on request
3) Lifetime guarantee is NOT available on this model

Datas are based on l = 1150mm, nylon wheels

Hand Pallet Truck variants	
Quick Lifter <ul style="list-style-type: none"> ● For customer applications calling for high volumes of pallet movements every day. ● The forks reach the pallet with the first pump stroke and lift the pallet with the second. ● Data: see LHM230Q above. 	Over load valve <ul style="list-style-type: none"> ● Possible as option for LHM230. ● Pre-set limitation of the weight that can be lifted. ● Protects the truck and floors from being over loaded.
Handbrake <ul style="list-style-type: none"> ● Possible as option for LHM230, LHM230Q and LHM300. ● Identical braking power on both steering wheels. ● Can be locked in parking position. 	Wet spec <ul style="list-style-type: none"> ● Based on a LHM230 standard adapted to be more suitable in humid applications. ● Stainless steel axles and bearings. ● Data: see LHM230 above.
Roll handling <ul style="list-style-type: none"> ● Possible as option for LHM230 and LHM300. ● Special forks for handling reel drums. ● Reel diameters from 400mm up to 1800mm. 	Heights <ul style="list-style-type: none"> ● BT offers following minimum heights, to be able to handle different type of pallets: ● 75 mm possible for LHM230 and LHM230Q. Capacity 2300 kg. ● 65 mm possible LHM230 and LHM230Q. Capacity 2000 kg. ● 55 mm possible for LHM230. Capacity 2000 kg.
Heavy Lifter <ul style="list-style-type: none"> ● For heavy duty applications which often require additional muscle. ● Lifting capacity up to 3.000 kg. ● Data: see LHM300 above. 	Accessories <ul style="list-style-type: none"> ● Load support ● Conveyor kit ● Parking brake ● Cold store ● Tow train
Other Hand Pallet Trucks	
Stainless Lifter <ul style="list-style-type: none"> ● Specially designed for corrosive environments or applications that demand high standards of hygiene. ● Data: see separate LHM200ST Product Information sheet. 	Pro Lifter <ul style="list-style-type: none"> ● Helps you get the hand pallet truck started. ● The required force to get it moving is reduced by two thirds. ● Smooth driving over uneven surfaces and thresholds and easy positioning of heavy loads. ● Data: see separate LHM230P, QP Product Information sheet.

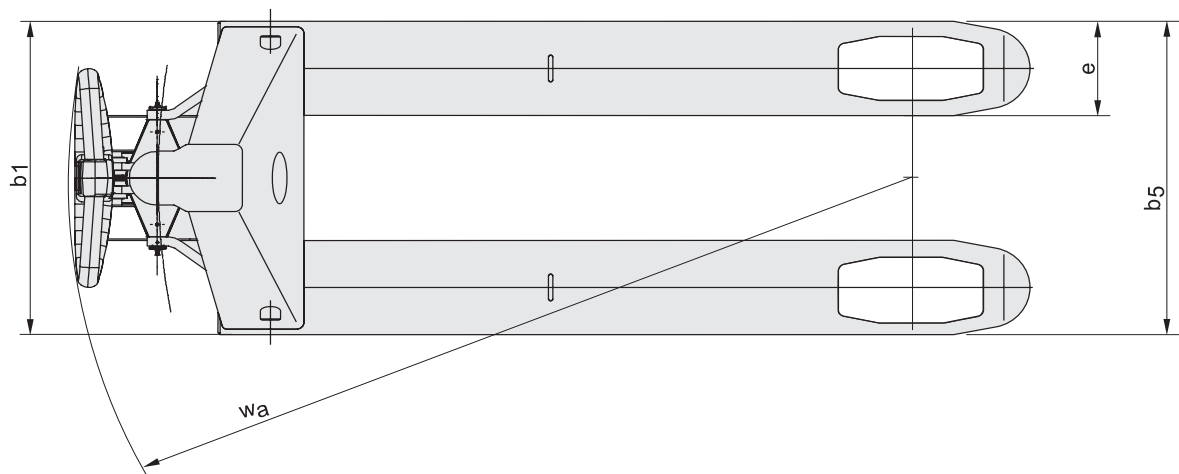
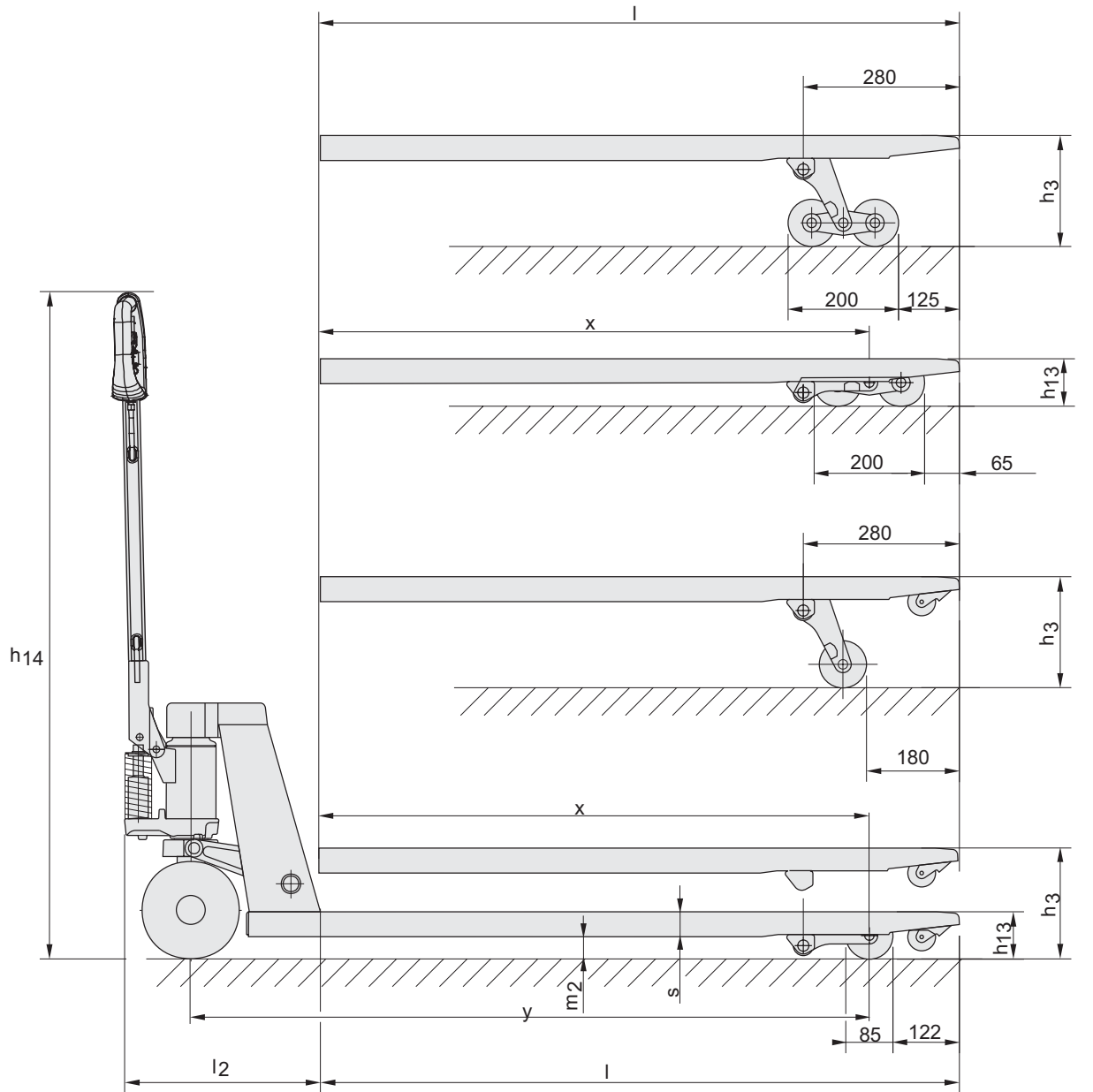



- Customized configurations and designs can be available on request.
- A large variety of wheel types: nylon, polyurethane, steel, polyurethane and rubber.
- 10/12 greasable bushings ensure a long service life.
- Welded tow bar attachment provides high reliability.
- Powder coating and robot welding give a high and even finish.
- Angled highstrength polymer handle for best ergonomic grip.
- BT's unique lifetime guarantee, gives the customer 99-years functional guarantee on the fork frame. The guarantee on the pump unit and the tow bar is five years.
- LHM230 has been environmentally declared. Separate information sheet is available.

Truck features	LHM230	LHM230Q	LHM300
Choice of chassis widths	S	S	S
Choice of fork lengths	S	S	S
Choice of wheel types	O	O	O
Climber wheels	S	S	S
Bogie fork wheels	O	O	O
Train version	O	O	—
Controls and instruments			
Tiller arm steering	S	S	S
Driving features			
180° steering	S	S	S
Safety features			
Handbrake	O	O	O
Parking brake	O	O	O
Load support	O	O	—
Maintenance features			
Lubrication points	S	S	S
Special applications			
Coldstore version	O	O	O

S = Standard feature

O = Optional feature

— = Not available